



Fermi National Accelerator Laboratory

FERMILAB-TM-1380

Revised November 2014

Mechanical Safety Subcommittee Guideline for Design of Thin Windows for Vacuum Vessels

Jeffrey L. Western

Fermi National Accelerator Laboratory

P.O. Box 500, Batavia, Illinois 60510

March 1991



Disclaimer

This report was prepared as an account of work sponsored by an agency of the United States Government. Neither the United States Government nor any agency thereof, nor any of their employees, makes any warranty, express or implied, or assumes any legal liability or responsibility for the accuracy, completeness, or usefulness of any information, apparatus, product, or process disclosed, or represents that its use would not infringe privately owned rights. Reference herein to any specific commercial product, process, or service by trade name, trademark, manufacturer, or otherwise, does not necessarily constitute or imply its endorsement, recommendation, or favoring by the United States Government or any agency thereof. The views and opinions of authors expressed herein do not necessarily state or reflect those of the United States Government or any agency thereof.

Mechanical Safety Subcommittee Guideline for Design of Thin Windows for Vacuum Vessels

by: Jeffrey L. Western

1. INTRODUCTION

This guideline specifies the usage of thin windows for vacuum vessels in terms of their design and application at Fermilab.

2. SCOPE

- 2.1 This guideline is to be applied to vacuum vessels when the pressure differential across the window is less than or equal to fifteen (15) psid.

$$dP \leq 15 \text{ psid} \quad (\text{equation 2.1})$$

- 2.2 This guideline will encompass thin windows consisting of circular, square and rectangular geometries.
- 2.3 This guideline shall fall under the scope of the "Fermilab Safety Manual", Vacuum Pressure Vessel Safety (5033).
- 2.4 Excluded from this guideline is windows for LH₂ targets which are included under "Guidelines for the Design, Fabrication, Testing, Installation and Operation of LH₂ Targets".

3. GENERAL GUIDELINES

- 3.1 A thin window is a diaphragm plate where the deflection is greater than 1/2 of the thickness. From Article 10.11, page 457 "Formulas for Stress and Strain" Sixth Edition.

$$y > t/2 \quad (\text{equation 3.1})$$

- 3.2** The allowable stress for thin windows shall be the most stringent of the following:

$$S = 0.5 F_U \quad \text{(equation 3.2a)}$$

or

$$S = 0.9 F_Y \quad \text{(equation 3.2b)}$$

- 3.2.1** Where:

S = allowable stress (psi)

F_U = ultimate tensile strength (psi)

F_Y = yield strength or stress to produce 5% elongation (psi)

- 3.3** Thin windows shall not be exposed to cyclic loading greater than 1000 load cycles. Negative load cycling is not allowed unless design and testing verifies performance.
- 3.4** The mounting flange shall have an edge radius to prevent the window from tearing.
- 3.5** Material documentation: Vendor material certification/ verification shall be included in window documentation.
- 3.6** Multi-layer mylar window: Mylar windows with a thickness greater than 0.010" shall have that thickness built up from multiple layers of mylar, with no single layer more than 0.010" thick.

4. GUIDELINES FOR FLEXIBLE MATERIAL WINDOWS

- 4.1** Flexible material circular windows such as mylar/kapton and titanium/stainless steel less than 0.003" ($t < 0.003"$). Design condition: held not fixed.
- 4.1.1** The allowable stress for circular windows shall be greater than the following: Derived from Equations 1 and 2, page 477, case number 4, page 478 "Formulas for Stress and Strain" Sixth Edition.

$$S > 0.423 (Eq^2a^2/t^2)^{1/3} \quad \text{(equation 4.1a)}$$

and the deflection is:

$$y = 0.662 a (qa/Et)^{1/3} \quad \text{(equation 4.1b)}$$

4.1.2 Where:

- t = thickness of window (inch)
- a = radius of window measured at O-ring on flange (inch)
- q = uniform pressure on window (psid)
- S = allowable stress (psi)
- E = Young's modulus of window material (psi)
- y = window deflection (inch)

4.2 Flexible material rectangular windows such as mylar/kapton and titanium/stainless steel less than 0.003" (t < 0.003"). Design condition: held not fixed.

4.2.1 The allowable stress for rectangular windows shall be greater than the following: From Brookhaven National Laboratory "Occupational Health and Safety Guide", Section 1.4.2, appendix B.

$$S > K_1 (E (qa/t)^2)^{1/3} \quad \text{(equation 4.2a)}$$

and the deflection is:

$$y = K_2 (qa^4/Et)^{1/3} \quad \text{(equation 4.2b)}$$

4.2.2 Where:

- t = thickness of window (inch)
- K₁ = stress constant based on ratio a/b (see table below)
- K₂ = deflection constant based on ratio a/b (see table below)
- a = short side of rectangular window measured at O-ring (inch)

- b** = long side of rectangular window measured at O-ring (inch)
q = uniform pressure on window (psid)
S = allowable stress (psi)
E = Young's modulus of window material (psi)
y = window deflection (inch)

4.2.3 Constant table for values of K for rectangular windows:

b/a	K₁	K₂
1.0	0.271	0.320
1.1	0.292	0.331
1.2	0.306	0.339
1.3	0.316	0.344
1.4	0.323	0.348
1.5	0.329	0.351
1.6	0.332	0.353
1.7	0.336	0.355
1.8	0.338	0.356
1.9	0.340	0.357
2.0	0.340	0.357
3.0	0.346	0.360
> 3.0	0.346	0.360

Note: K₁ values for maximum stress at center of window.

5. GUIDELINES FOR RIGID MATERIAL WINDOWS

5.1 Rigid material circular windows such as titanium and stainless steel greater than 0.003" (**t > 0.003"**). Design condition: held and fixed.

5.1.1 The allowable stress for circular windows shall be greater than the stress obtained by solving by trial and error equation 5.1b for deflection and then substitute into 5.1a. See equations 1 and 2, page 477, case number 3, page 478 "Formulas for Stress and Strain" Sixth Edition.

$$S > E(t/a)^2[K_3(y/t) + K_4(y/t)^2] \quad (\text{equation 5.1a})$$

and the deflection can be calculated from:

$$qa^4/Et^4 = K_1(y/t) + K_2(y/t)^3 \quad (\text{equation 5.1b})$$

5.1.2 Where:

- t** = thickness of window (inch)
 - a** = radius of window measured at O-ring on flange (inch)
 - q** = uniform pressure on window (psid)
 - S** = allowable stress (psi)
 - E** = Young's modulus of window material (psi)
 - y** = window deflection (inch)
 - K₁** = $5.33/(1-\nu^2)$
 - K₂** = $2.6/(1-\nu^2)$
 - K₃** = $2.0/(1-\nu)$
 - K₄** = 0.976
 - ν** = poisson's ratio
- Note:** K values
for maximum stress
at center of window.

5.2 Rigid material rectangular windows such as titanium and stainless steel greater than 0.003" ($t > 0.003$ "). Design condition: held and fixed.

5.2.1 The allowable stress for rectangular windows shall be greater than the stress obtained by solving by trial and error equation 5.2b for deflection and then substitute into 5.2a. From Brookhaven National Laboratory "Occupational Health and Safety Guide", Section 1.4.2, appendix C.

$$S > E(t/a)^2[K_3(y/t) + K_4(y/t)^2] \quad (\text{equation 5.2a})$$

and the deflection can be calculated from:

$$qa^4/Et^4 = K_1(y/t) + K_2(y/t)^3 \quad (\text{equation 5.2b})$$

5.2.2 Where:

- t** = thickness of window (inch)
K₁ = stress constant based on ratio a/b (see table below)
K₂ = deflection constant based on ratio a/b (see table below)
a = short side of rectangular window measured at O-ring (inch)
b = long side of rectangular window measured at O-ring (inch)
q = uniform pressure on window (psid)
S = allowable stress (psi)
E = Young's modulus of window material (psi)
y = window deflection (inch)

5.2.3 Constant table for values of K for rectangular windows:

b/a	K ₁	K ₂	K ₃	K ₄
1.0	72.5	30.5	22.3	2.7
1.1	60.9	27.6	21.3	2.7
1.2	53.2	25.7	20.4	2.7
1.3	47.9	24.6	19.7	2.7
1.4	44.3	23.7	19.3	2.7
1.5	41.5	23.1	18.9	2.7
1.6	39.8	22.7	18.7	2.7
1.8	37.5	22.2	18.3	2.7
2.0	36.1	22.0	18.0	2.7
> 2.0	35.2	21.4	17.6	2.7

Note: K₃ and K₄ values for maximum stress at the midpoint of the long edge of window.

6. RESPONSIBILITY / DOCUMENTATION

The responsibility and documentation for thin windows shall follow the "Fermilab Safety Manual", Vacuum Pressure Vessel Safety (5033).

APPENDIX A**EXAMPLE 1: Circular flexible window**

Circular 3" diameter by 0.005" thickness Mylar window under vacuum.

- t** = 0.005": thickness of window (inch)
a = 1.5": radius of window measured at O-ring on flange (inch)
q = 14.7 psi: uniform pressure on window (psid)
S = $0.5 F_U = 0.5 \times 25,000 \text{ psi} = \underline{12,500 \text{ psi}}$ or
 $0.9 F_Y = 0.9 \times 15,000 \text{ psi} = 13,500 \text{ psi}$:
allowable stress (psi)
E = 500,000 psi: Young's modulus of window material (psi)
y = window deflection (inch) \leq to be calculated

From TM-1380 Page 2, Section 4.1, Circular window with edge held but not fixed.

$$S > 0.423 (Eq^2a^2/t^2)^{1/3} \quad \text{(equation 4.1a)}$$

$$12,500 \text{ psi} > 0.423 [(500,000)(14.7)^2(1.5)^2/0.005^2]^{1/3}$$

$$12,500 \text{ psi} > \underline{9,029 \text{ psi}} \Rightarrow \text{Adequate}$$

and the deflection is:

$$y = 0.662 a (qa/Et)^{1/3} \quad \text{(equation 4.1b)}$$

$$y = 0.662 (1.5) [(14.7)(1.5)/(500,000)(0.005)]^{1/3}$$

$$y = \underline{0.205 \text{ inch}} \leq \text{Deflection}$$

and: $y > t/2 \quad \text{(equation 3.1)}$

$$0.205" > 0.005"/2$$

$$0.205" > 0.0025" \Rightarrow \text{Adequate}$$

APPENDIX A**EXAMPLE 2: Square flexible window**

Square 3" by 0.009" thickness Kapton window under vacuum.

- t** = 0.009": thickness of window (inch)
a = 3.0": short side of rectangular window measured at O-ring (inch)
b = 3.0": long side of rectangular window measured at O-ring (inch)
q = 14.7 psi: uniform pressure on window (psid)
S = $0.5 F_U = 0.5 \times 25,000 \text{ psi} = 12,500 \text{ psi}$ or
 $0.9 F_y = 0.9 \times 12,500 \text{ psi} = \underline{11,250 \text{ psi}}$:
allowable stress (psi)
E = 400,000 psi: Young's modulus of window material (psi)
y = window deflection (inch) <= to be calculated

From TM-1380 Page 3, Section 4.2, Rectangular window with edge held but not fixed.

from table 4.2.3: for $b/a = 3.0/3.0 = 1 \implies K_1 = 0.271$ & $K_2 = 0.320$

$$S > K_1 [E(qa/t)^2]^{1/3} \quad \text{(equation 4.2a)}$$

$$11,250 \text{ psi} > 0.271 [(400,000)(14.7)^2(3.0)^2 / (0.009)^2]^{1/3}$$

$$11,250 \text{ psi} > \underline{5760 \text{ psi}} \implies \text{Adequate}$$

and the deflection is:

$$y = K_2 (qa^4/Et)^{1/3} \quad \text{(equation 4.2b)}$$

$$y = 0.320 [(14.7)(3.0)^4 / (400,000)(0.009)]^{1/3}$$

$$y = \underline{0.221 \text{ inch}} \leq \text{Deflection}$$

and: $y > t/2$ (equation 3.1)

$$0.221" > 0.009"/2$$

$$0.221" > 0.0045" \implies \text{Adequate}$$

APPENDIX A

EXAMPLE 3: Circular rigid window

Circular 6" diameter by 0.005" thickness stainless steel (work hardened 302 S.S.) window under vacuum.

- t** = 0.005": thickness of window (inch)
- a** = 3.0": radius of window measured at O-ring on flange (inch)
- q** = 14.7 psi: uniform pressure on window (psid)
- S** = $0.5 F_u = 0.5 \times 250,000 \text{ psi} = \underline{125,000 \text{ psi}}$ or
 $0.9 F_y = 0.9 \times 150,000 \text{ psi} = 135,000 \text{ psi}$:
 allowable stress (psi)
- E** = 30E6 psi: Young's modulus of window material (psi)
- v** = 0.3 : poisson's ratio
- y** = window deflection (inch) <= to be calculated

From TM-1380 Page 4, Section 5.1, Circular window with edge held and fixed.

from section 5.1.2: for $v = 0.3 \Rightarrow K_1 = 5.86, K_2 = 2.86, K_3 = 2.86, K_4 = .976$

deflection is: $qa^4/Et^4 = K_1(y/t) + K_2(y/t)^3$ (equation 5.1b)

$$14.7(3.0)^4/30E6(.005)^4 = 5.86 (y/.005) + 2.86 (y/.005)^3$$

$$y = \underline{0.14 \text{ inch}} \text{ <= Deflection.....solved by trial and error}$$

where: $y > t/2$ (equation 3.1)

$$0.14" > 0.005"/2$$

$$0.14" > 0.0025" \Rightarrow \text{Adequate}$$

stress is: $S > E(t/a)^2[K_3(y/t) + K_4(y/t)^2]$ (equation 5.1a)

$$125,000 \text{ psi} > (30E6)(.005/3.0)^2[2.86(.14/.005) + 0.976(.14/.005)^2]$$

$$125,000 \text{ psi} > \underline{38,817 \text{ psi}} \Rightarrow \text{Adequate}$$

APPENDIX A**EXAMPLE 4: Rectangular rigid window**

Rectangular 6" x 9" by 0.006" thickness titanium (6AL-4V) window under vacuum.

- t** = 0.006": thickness of window (inch)
a = 6.0": short side of rectangular window measured at O-ring (inch)
b = 9.0": long side of rectangular window measured at O-ring (inch)
q = 14.7 psi: uniform pressure on window (psid)
S = $0.5 F_u = 0.5 \times 130,000 \text{ psi} = \underline{65,000 \text{ psi}}$ or
 $0.9 F_y = 0.9 \times 120,000 \text{ psi} = 108,000 \text{ psi}$:
allowable stress (psi)
E = 16E6 psi: Young's modulus of window material (psi)
v = 0.3 : poisson's ratio
y = window deflection (inch) <= to be calculated

From TM-1380 Page 5, Section 5.2, Rectangular window with edge held and fixed.

from table 5.2.3: for $b/a = 1.5 \Rightarrow K_1 = 41.5, K_2 = 23.1, K_3 = 18.9, K_4 = 2.7$

deflection is: $qa^4/Et^4 = K_1(y/t) + K_2(y/t)^3$ **(equation 5.2b)**

$$14.7(6.0)^4/16E6(.006)^4 = 41.5 (y/.006) + 23.1 (y/.006)^3$$

$$y = \underline{0.21 \text{ inch}} \text{ <= Deflection.....solved by trial and error}$$

where: $y > t/2$ **(equation 3.1)**

$$0.21" > 0.006"/2$$

$$0.21" > 0.003" \Rightarrow \text{Adequate}$$

stress is: $S > E(t/a)^2[K_3(y/t) + K_4(y/t)^2]$ **(equation 5.2a)**

$$65,000 \text{ psi} > (16E6)(.006/6.0)^2[18.9(.21/.006) + 2.7(.21/.006)^2]$$

$$65,000 \text{ psi} > \underline{63,504 \text{ psi}} \Rightarrow \text{Adequate}$$

November 1992

Practical Guidelines and Parameters for Thin Windows Used on Vacuum Vessels.

Addendum to FERMILAB-TM-1380

Extracted in part from Brookhaven National Laboratory Occupational Health and safety Guide (Glass and Plastic Window Design for Pressure Vessels 1.4.2 , Feb., 1980)

1. Parameters. The following distance relationships should be observed, see figure 1, 2 & 3

(a) The distance from the bolt hole to O-ring groove (B) shall be at least $2/3$ of the bolt diameter.

(b) The distance from the O-ring groove to the window opening (A) should be at least $1/8$ " plus the edge radius.

(c) The window opening edge radius should be a minimum of 15 times the window thickness although 25 is preferred.

(d) For rectangular window mounts, the corner radius shall be a minimum of 0.15 of the shortest span of the window opening, see figure 3.

2. Guidelines

(a) Clamping surfaces should be flat to within 0.0015"/foot.

(b) The clamping bolts shall be designed to exert a clamping force that is a minimum of 3 times the force applied to the window.

(c) The clamping ring must be rigid enough to maintain adequate clamping force between bolts.

(d) Flat washers shall be used under the bolt heads to prevent galling and to ensure the application of the proper torque value.

(e) All bolt holes, in the window, shall be punched with a sharp edged punch. Deburr all holes after punching, do not burn the holes. Normal clearance hole practice should be applied.

(f) All surfaces shall be 64 micro-inches or better and free of burrs and sharp edges.

3. Plastics windows with "fixed and held mounts. (Figure 2)

(a) The clamping ring and vessel wall must be rigid enough to prevent any local deflections that would permit angular rotation of the window edges.

(b) The window must have significant flexural stiffness. See notes 1 & 2 of figure 2.

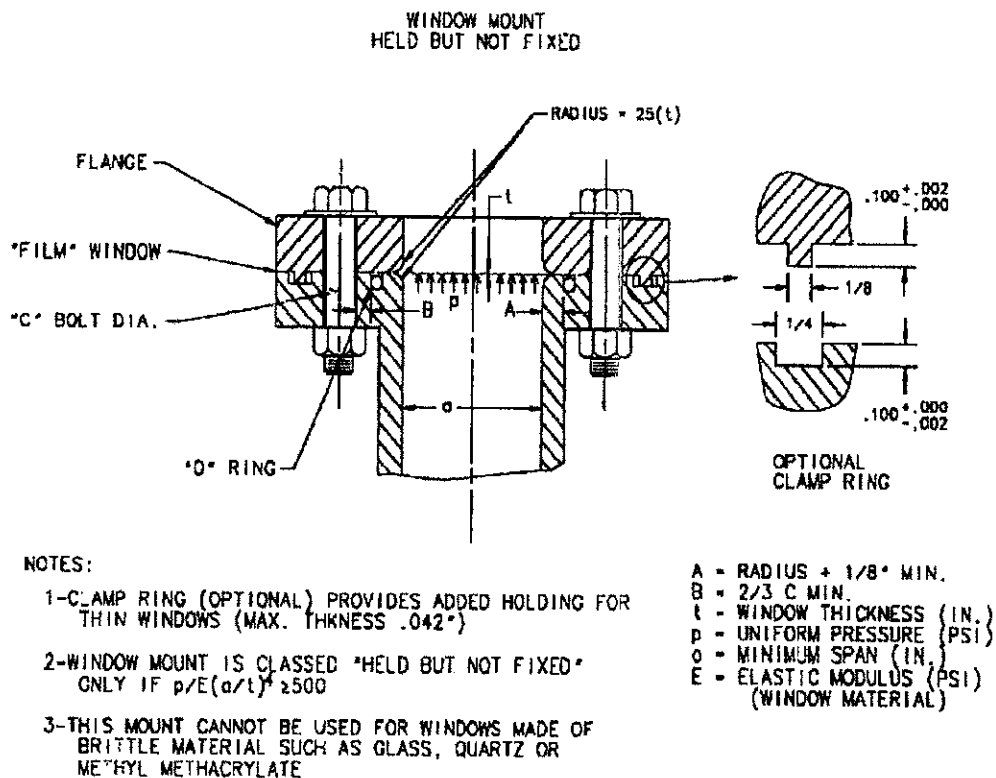
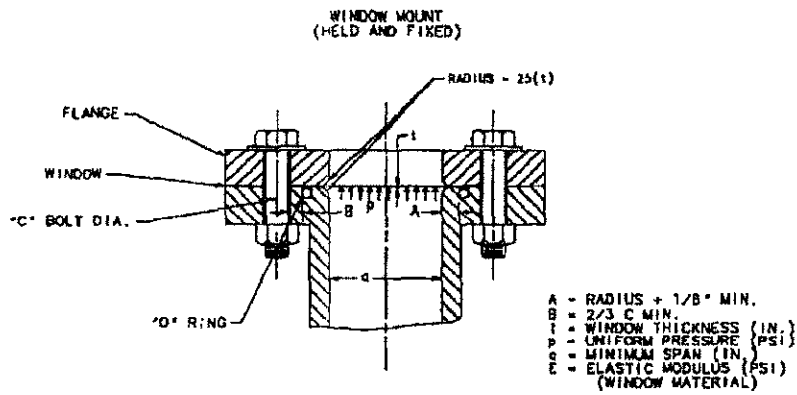

FIG. 1



NOTES:

1-WINDOW MOUNT IS CLASSED "HELD AND FIXED" ONLY IF $p/E(c/t)^3 < 500$ AND THE STRESS AT THE EDGES IS BELOW THE YIELD POINT OF THE WINDOW MATERIAL.

2-WINDOW MOUNT IS CLASSED "HELD BUT NOT FIXED" IF EITHER OR BOTH CONDITIONS IN NOTE 1 ARE EXCEEDED.

FIG. 2

FLANGE FOR RECTANGULAR FILM WINDOWS

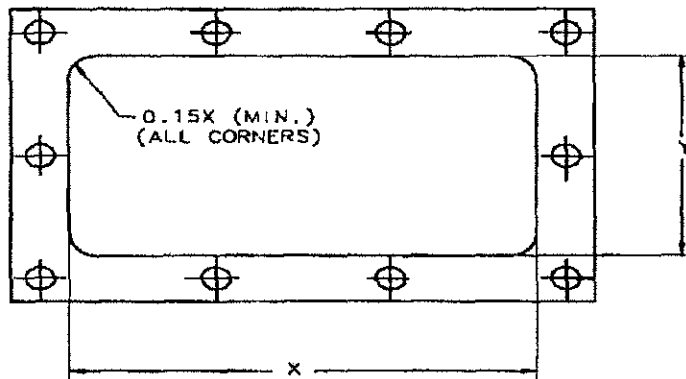

NOTES:

1-WHERE "X" IS SMALLER OR EQUAL TO "Y"

2-ALL OTHER DIMENSIONS, REFER TO FIG. 1 & 2

FIG. 3

