

FESHM 5031.2: INERT GAS TRAILER CONNECTIONS, USE, AND ONSITE FILLING

Revision History

Author	Description of Change	Revision Date
Lidija Kokoska	<ul style="list-style-type: none">• Updated header to match standard format• Clarified training requirements in Section 4.4	October 2022
Dave Pushka	<ul style="list-style-type: none">• Updated formatting,• Added Mechanical Safety Subcommittee responsibility for chapter maintenance,• Addressed use of flexible piping element upstream of regulator,• Added recording of training in TRAIN database.	November 2017
William Soyars	Title deleted word Guideline. Clarifications made in Section 1.0, 8.0, 9.0. No change to technical content.	September 2014
Thomas Page	Re-release of Chapter 5031.2 with no revisions to content. Added FESHM Chapter template.	November 2011

TABLE OF CONTENTS

1.0	INTRODUCTION.....	3
2.0	DEFINITIONS	3
3.0	RESPONSIBILITIES.....	3
4.0	PROCEDURES	4
4.1	MANIFOLD REQUIREMENTS	4
4.2	FLEXIBLE TUBING OR HOSE REQUIREMENTS	5
4.3	RECOMMENDED MANIFOLD CONFIGURATION FOR HELIUM TRAILERS	6
4.4	RECOMMENDED TRAINING AND DOCUMENTATION FOR FERMILAB PERSONNEL WHO REGULARLY ENGAGE IN REFILLING PROCEDURES.....	7
4.5	SUGGESTED INERT GAS TUBE TRAILER VENDOR ONSITE DELIVERY PROCEDURES FOR FILLING CLEAN INERT GAS HIGH PRESSURE SYSTEMS..	7

1.0 INTRODUCTION

This chapter outlines recommended system configurations for tube trailer connections for inert, non-flammable gases in use at Fermilab and any leased spaces. (For flammable gases, reference FESHM 6020.3.) This chapter also outlines the recommended training and documentation for Fermilab personnel who regularly engage in gas transfer activities (Refer to section 4.4). Inert gases are non-flammable and include helium, nitrogen, argon or dry air. This chapter specifies

- A. required fittings and components for helium tube trailer manifolds and high pressure hose assemblies which are used for the filling of reduced pressure systems from high pressure helium tube trailers. (Helium requirements are specifically addressed due to large number of trailers used around the laboratory and for compatibility with vendor deliveries.)
- B. flexible tubing or hose requirements and recommended manifold configurations with pressure regulators
- C. the recommended guidelines for onsite helium tube trailer refilling by vendors.

The philosophy of the connection from the tube trailer shall be to minimize the amount of high pressure piping and use flexible hose or tubing in the low pressure piping. In the event flexible hose or tubing exists, the low pressure ends shall be restrained to prevent "whipping."

2.0 DEFINITIONS

Whipping - dangerous unconstrained motion of the end of a high pressure flexible hose which is discharging high pressure inert gases to atmospheric pressure.

Drive-away accident - driving a tube trailer away without removing the connection hose from the manifold thereby damaging the connection hose, manifold and fittings.

Safety chain - any link chain, safety strap, or reinforced cable which can withstand a design load of 1400 lb.

3.0 RESPONSIBILITIES

It is the responsibility of the division/section transferring or receiving inert gases at high pressure to assure compliance with this chapter.

Maintenance of this chapter is the responsibility of the Mechanical Safety Subcommittee.

4.0 PROCEDURES

4.1 MANIFOLD REQUIREMENTS

Any Fermilab Owned Tube Trailer Manifold Used For Delivery Of Inert Gases To Other Inert Gas Systems Shall Have:

1. All hard piped branch supply valves and suitably rated male high pressure supply fittings. For helium trailers, there must be at least one male high pressure O-ring fitting #53T-5-SS supplied by Combination Pump Valve Company (CPV).
2. A permanently attached pressure rated protective cap for the CPV high pressure O-ring fitting #53T-5-SS (Union nut 50N-5 bronze, blank fitting #1048-5 Stainless Steel).
3. A "safety chain" termination no further than 12" away from the male high pressure fitting for reversed flow situations.
4. A suitably rated accurate pressure gauge in the trailer manifold.
5. A suitably rated accurate temperature gauge in the trailer manifold.
6. A device to prevent a "Drive-away Accident" from causing personnel injury or serious system damage (e.g., wheel chocks, Hydraulic cut-off flag).

All piping systems associated with delivering pressurized gas from trailer manifolds must meet the requirements of [FESHM 5031.1](#), "Piping Systems."

Any Fermilab Owned Tube Trailer Manifold Used For Delivery Of Inert Gas To Other Inert Gas Systems Shall Not Have:

1. A flexible hose or element attached directly to the inert gas tube trailer high pressure manifold.

Any Fermilab Owned Tube Trailer Manifold Used For Delivery Of Inert Gas To Other Inert Gas Systems May Have:

1. A hard piped pressure rated purge valve between the branch supply valve and suitably rated high pressure fitting.
2. Extra ports capped with pressure rated caps.

4.2 FLEXIBLE TUBING OR HOSE REQUIREMENTS

Any Flexible Tubing Or Hose For Connection Between Fermilab Owned Or Leased Tube Trailers And Other Inert Gas Systems Shall Have:

1. A suitably rated tubing or hose as the flexible element. If stainless steel is used, 316 is recommended for its resistance to chloride corrosion.
2. A "Safety Chain" which is solidly attached to the flexible hose, mounted within the last 12" of the low pressure end of the flexible hose. The "Safety Chain" shall be connected in such a manner that "whipping" will not loosen or remove the "Safety Chain" from either end termination.
3. End connectors rated for the highest system pressure.

Any Flexible Tubing Or Hose For Connection Between Fermilab Owned Or Leased Tube Trailers And Other Inert Gas Systems Shall Not:

1. Be attached directly (without a shut-off valve) to the inert gas tube trailer high pressure manifold.
2. A flexible hose may be used downstream of a shut off valve as shown on the right hand side of figure 1 as long as a piping engineering note has been written, reviewed, and approved that specifically addresses the flexible tubing or hose and shows the flexible item is sufficient for the service, including meeting all code requirements.

Any Flexible Tubing Or Hose For Connection Between Fermilab Owned Or Leased Tube Trailers And Other Inert Gas Systems May Have:

1. Hard piped pressure rated purge valve adapter (see figure #1, AV2 or AV3).
2. Non-standard female high pressure rated fittings which are connected to alternate delivery systems.

4.3 RECOMMENDED MANIFOLD CONFIGURATION FOR HELIUM TRAILERS

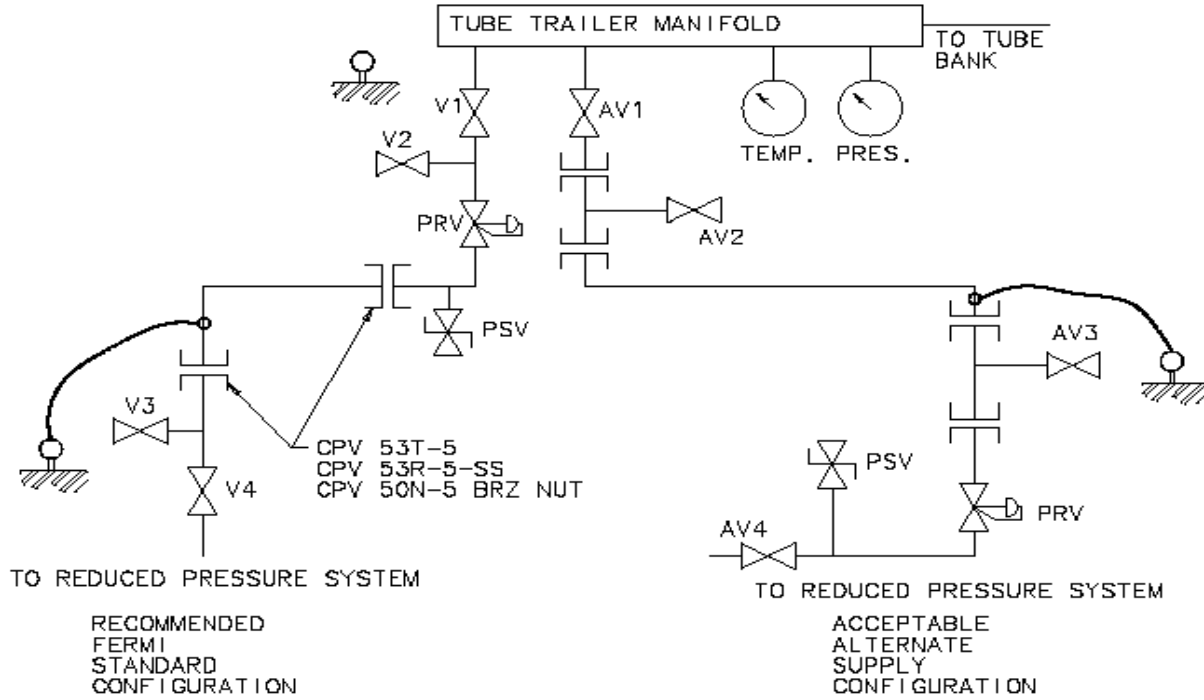

FIGURE #1

4.4 RECOMMENDED TRAINING AND DOCUMENTATION FOR FERMILAB PERSONNEL WHO REGULARLY ENGAGE IN REFILLING PROCEDURES

In addition to [FN000605/CB/1] Hazardous Energy Control for Pressurized Systems, personnel who engage in the refilling of pressure systems from Fermilab owned or leased trailers should be trained on an annual basis on the proper refilling procedures for their respective systems. Documentation should include the name of the trained individual, the date of training, and be recorded in the TRAIN database as on-the-job (OTJ) training.

Personnel who engage in the use of, or refilling of pressure systems from Fermilab owned or leased trailers that include flexible tubing or hoses on the high pressure side shall be trained on an annual basis on the proper refilling procedures for their respective systems and on the dangers associated with high pressures flexible piping elements. This training is Mandatory and shall be recorded in TRAIN as OTJ training.

4.5 SUGGESTED INERT GAS TUBE TRAILER VENDOR ONSITE DELIVERY PROCEDURES FOR FILLING CLEAN INERT GAS HIGH PRESSURE SYSTEMS.

Any vendor inert gas tube trailer should have a delivery hose with a safety chain attached to the low pressure end which is capable of attaching to a safety chain termination located within 12" of the receiving fitting. Tube trailer to tube trailer transfers are referred to as cascade fills. Any vendor delivering inert gas to Fermilab high pressure systems should follow this procedure:

1. Ensure all tube isolation valves are closed.
2. Connect hose - attach safety chains.
3. Ensure fitting is not leaking by cracking V-1, pressurizing the line, and closing V-1.
4. Open V-3 and purge line, leaving a slight positive pressure. Repeat cracking, closing and purging one more time.
5. Close V-3, open trailer tube isolation valves. Open V-2 and start fill.
6. When Fermilab trailer is filled, shut V-2 and all tube isolation valves on trailers that were opened.
7. Bleed down hose through V-3.
8. Disconnect hose, remove safety chains and cover fitting with Fermilab supplied cap.

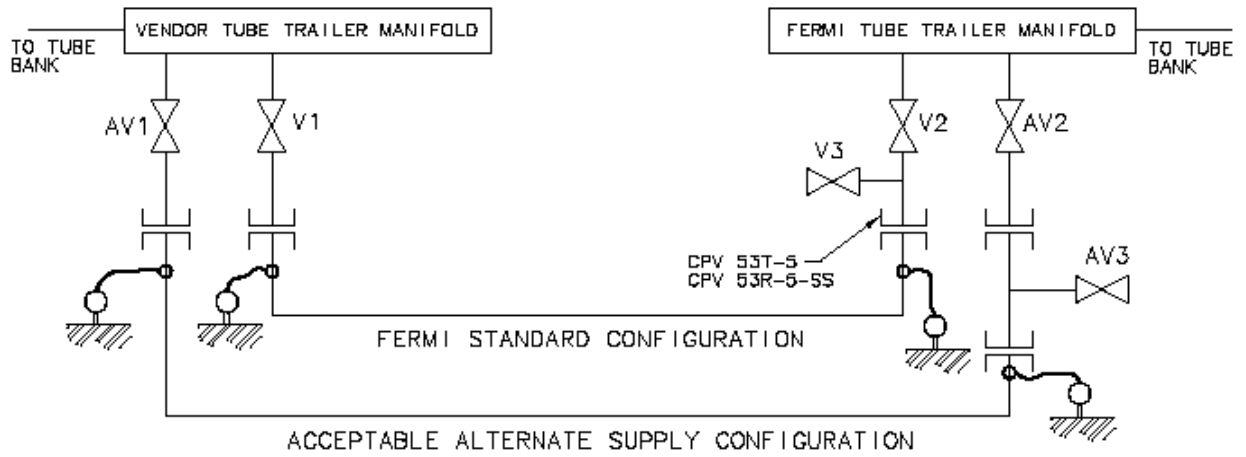

FIGURE #2